



GREEK RELATIVE CLAUSES

Prof. Vanessa Gorman
University of Nebraska-Lincoln
vgorman1@unl.edu

A relative clause is a subordinate clause that is not introduced by a subordinating conjunction.

Instead it contains a relative pronoun, adjective, or adverb that modifies a word in another clause [whether expressed or elided].

Translated “who,” “whose,” “whom,”
“which,” “that,” [“where,” “when”]

Terminology of Relative Clauses

Antecedent = the word modified by the relative clause

Definite Relative Clause = refers to a specific antecedent

- *Alkibiades, whose father died when he was young, grew up in Perikles' house.*
- *The vase that has a crack in it was damaged in transport.*

Indefinite Relative Clause = no specific antecedent

[“anyone” or “whoever”]

- *Whoever comes in late will be penalized.*
- *The man who invades Attica will be defeated.*
 - [i.e., any man who does so]

Terminology

Restrictive Relative Clause

- Defines the antecedent. It is necessary to understand the sentence.
- Is not enclosed in commas in English; neuters are translated “that.”
- *The vase that has a crack in it was damaged in transport.*
- *The sailor who survived the battle gave an account of the loss.*

Non-restrictive Relative Clause [Digressive]

- Offers additional information. Can be omitted without changing the meaning of the sentence.
- Is enclosed in commas; neuters are translated “which.”
- *Alkibiades, whose father died when he was young, grew up in Perikles’ house.*
- *The vase, which has a crack in it, was used to collect ballots.*

Relative Clauses

The relative pronoun/adjective matches its antecedent in gender and number

It derives its case from its use in the subordinate clause.

- *She gave the ring to her brother, who was older than she was.*
- *She gave the ring to her brother, whose wife had died.*
- *She gave the ring to her brother, to whom their father had entrusted his cattle.*
- *She gave the ring to her brother, whom the city exiled.*

Each relative pronoun here will be masculine singular to match “brother”

- The case will vary according to the syntax of the clause

Case	Sing	Pl		Sing	Pl		Sing	Pl
Nom	ὁ	οἱ		ἡ	αἱ		τὸ	τὰ
Gen	τοῦ	τῶν		τῆς	τῶν		τοῦ	τῶν
Dat	τῷ	τοῖς		τῇ	ταῖς		τῷ	τοῖς
Acc	τὸν	τούς		τήν	τάς		τὸ	τὰ

Definite Article

Case	Sing	Pl		Sing	Pl		Sing	Pl
Nom	ὁ	οἱ		ἡ	αἱ		τὸ	τὰ
Gen	τοῦ	τῶν		τῆς	τῶν		τοῦ	τῶν
Dat	τῷ	τοῖς		τῇ	ταῖς		τῷ	τοῖς
Acc	τὸν	τούς		τήν	τάς		τὸ	τὰ

Definite Article
omit tau; add rough
breathing and accent

Case	Sing	Pl	Sing	Pl	Sing	Pl
Nom	ὁ	οἱ	ἡ	αἱ	τὸ	τὰ
Gen	τοῦ	τῶν	τῆς	τῶν	τοῦ	τῶν
Dat	τῷ	τοῖς	τῇ	ταῖς	τῷ	τοῖς
Acc	τὸν	τούς	τήν	τάς	τὸ	τὰ

Definite Article
omit tau; add rough
breathing and accent

=

Definite Relative
Pronoun

("who"; "which/that")

Add a sigma to the
masc nom sg

Case	Sing	Pl	Sing	Pl	Sing	Pl
Nom	ὁς	οἱ	ἡ	αἱ	ὃ	ἅ
Gen	οῦ	ῶν	ῆς	ῶν	οὔ	ῶν
Dat	ῷ	οῖς	ῇ	αῖς	ῷ	οῖς
Acc	ὄν	οῦς	ῆν	ἄς	ὄ	ἅ

****Making a tree****

The verb of the relative clause hangs on the antecedent.

- If the antecedent is a noun, it hangs as an ATR.
- If the antecedent is an ADV, it hangs as an ADV.

Φιλοκλῆς δ' ἦν στρατηγὸς τῶν Ἀθηναίων, ὃς τούτους
διέφθειρεν. [2.1.31]

*Philokles was the Athenian
general who killed them.*

Antecedent = στρατηγός

- Gender + number = masc sg

Nominative = SBJ of clause

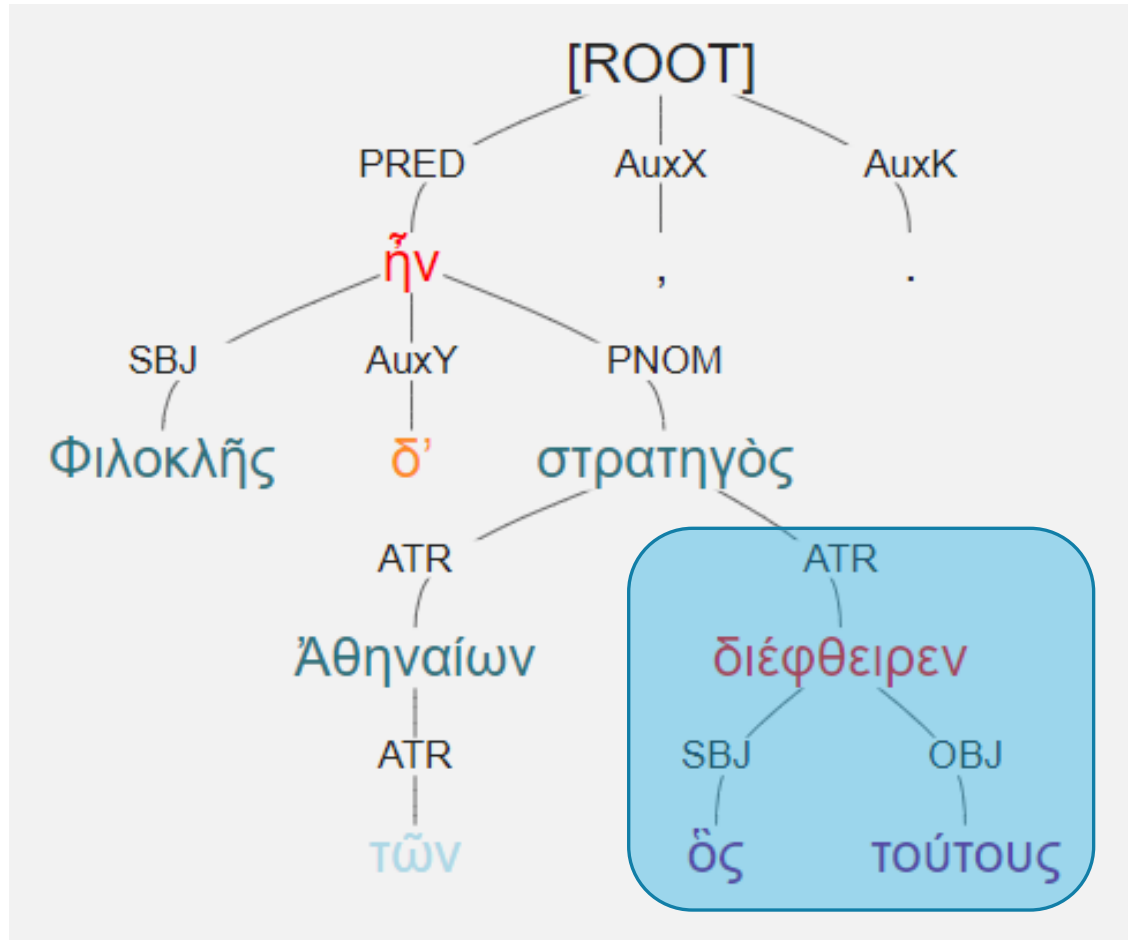

ἀξίαν δὲ καὶ ὅλην τὴν πόλιν ἐν ᾗ ἦν τὴν Ἐφεσον θεὰς
ἐποίησεν. [3.4.17]

*He made even the entire city,
Ephesos, in which he was
staying, worthy of the goddess.*

Antecedent = πόλις = fem sg

Function in clause =

obj of prep. = dat

Acting as PNOM in clause

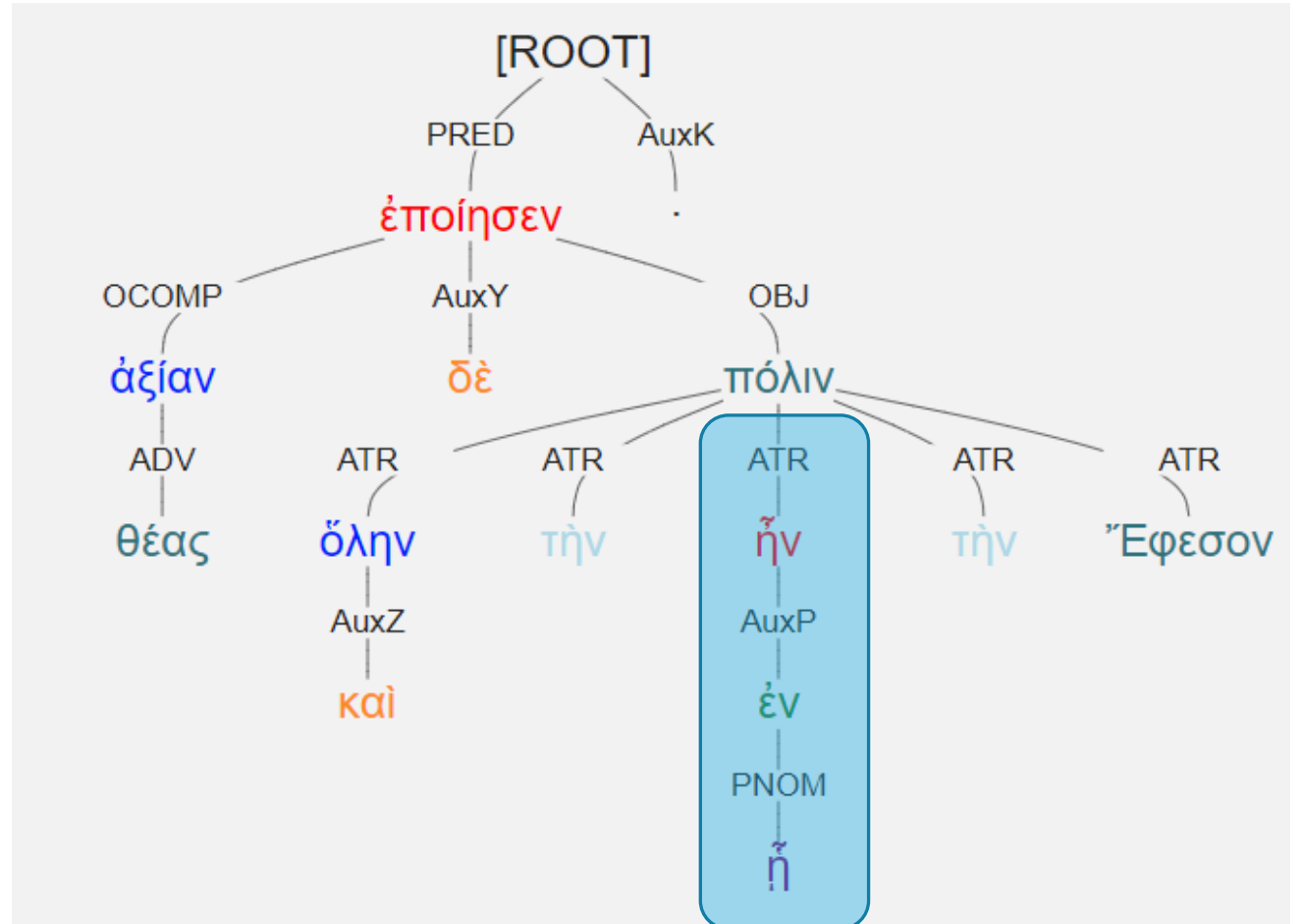

****Making a tree****

The verb of the relative clause hangs on the antecedent.

- If the antecedent is a noun, it hangs as an ATR.
- If the antecedent is an ADV, it hangs as an ADV.

If the antecedent is elided, then the verb of the clause stands in for the antecedent in the main clause and is labeled appropriately.

κἀκεῖνος μέντοι προθύμως ὅπερ ἐδεήθη ὁ Κῦρος ἔπραξεν. [3.1.1]

And of course that man did eagerly the very thing that Cyrus asked.

No expressed antecedent [τοῦτο or similar] = nt sg

- The verb of the clause is labeled as the antecedent would have been

Accusative = OBJ in clause

μέντοι implies a strong protestation

-περ on the relative is an intensifier

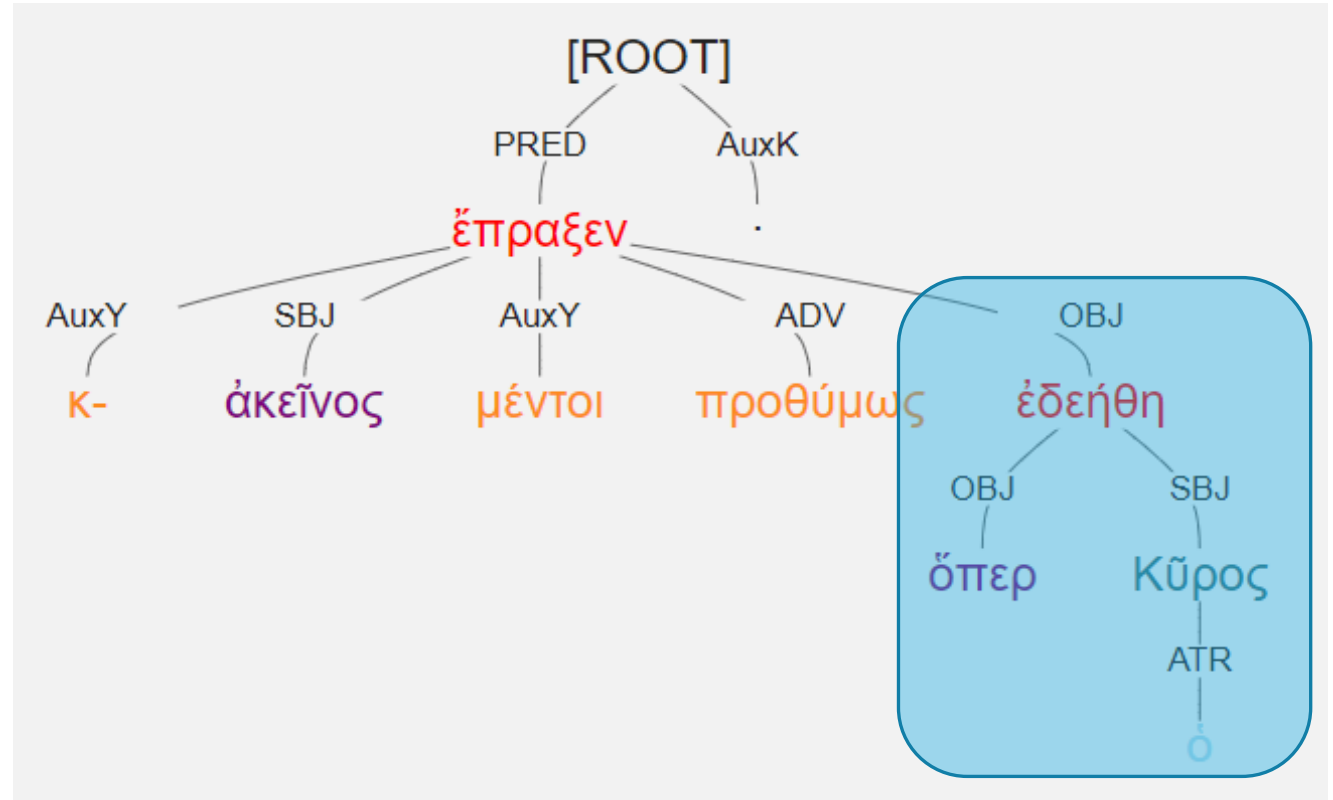

οὐκέτι ἀνέμενε τὸ ἀπὸ Λακεδαίμονος στράτευμα, ἀλλὰ σὺν οἷς εἶχεν ἦει πρὸς τὸ τεῖχος τῶν Ἰλιαρτίων. [3.5.18]

The army from Lakedaimon no longer waited, but it came to the walls of Haliartios with those it had.

Relative Attraction

The relative pronoun is **attracted** to the case of its missing antecedent.

- Only in restrictive clauses
- Only when the relative pronoun should be accusative
- Only when the antecedent should be genitive or dative [often with prep]

The labels are messed up accordingly.

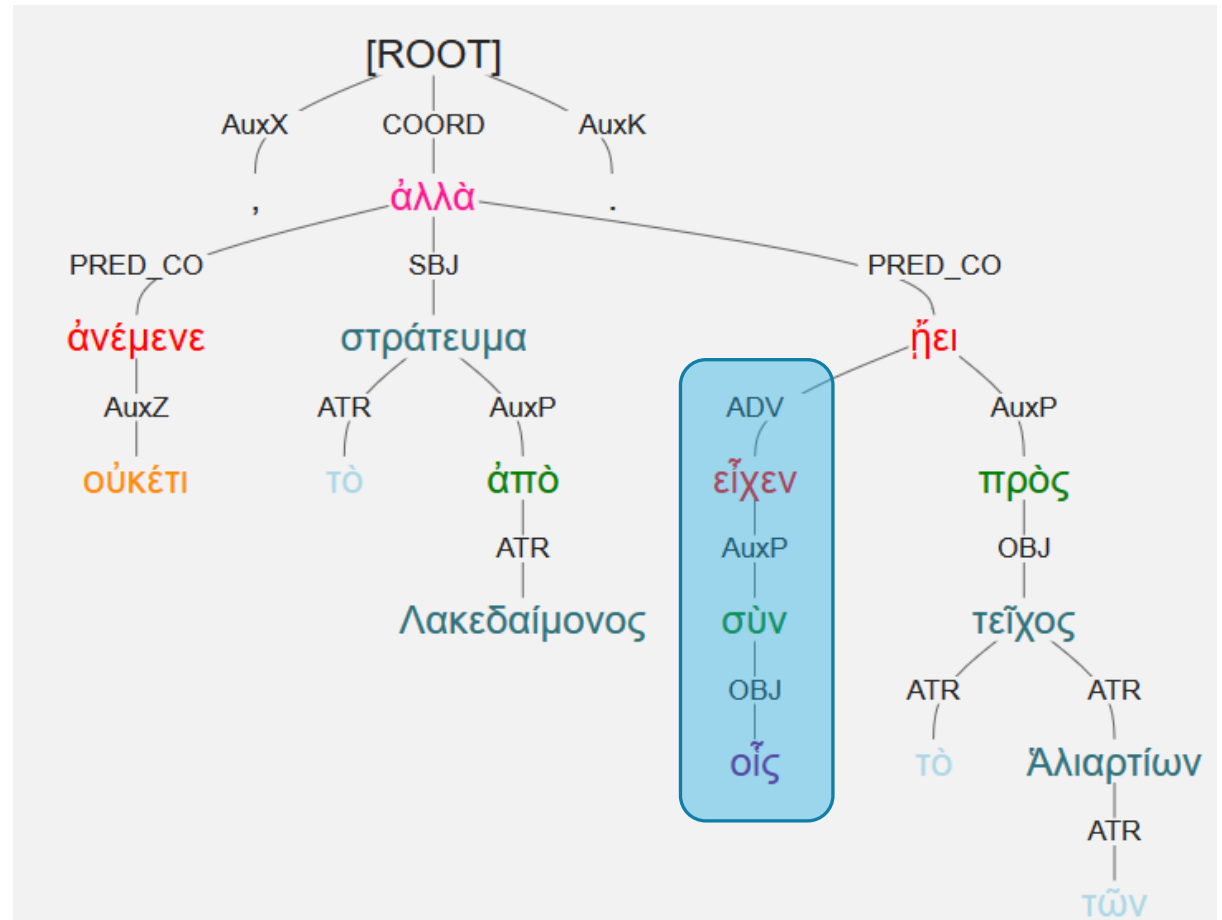

Case	Sing	Pl		Sing	Pl		Sing	Pl
Nom	ὁς	οἱ		ἡ	αἱ		ὁ	ἅ
Gen	οὗ	ῶν		ἥς	ῶν		οὗ	ῶν
Dat	ᾧ	οἷς		ἣ	αἷς		ᾧ	οἷς
Acc	ὄν	ούς		ἣν	ὰς		ὄ	ἅ

Definite relative pronoun

Case	Sing	Pl		Sing	Pl		Sing	Pl
Nom	ὁς	οἱ		ἡ	αἱ		ὁ	ἅ
Gen	οὔ	ῶν		ῆς	ῶν		οὔ	ῶν
Dat	ῶ	οῖς		ῆ	αῖς		ῶ	οῖς
Acc	ὄν	οὔς		ἦν	ἄς		ὄ	ἄ

Definite relative pronoun
+
indefinite pronoun/adjective

τις	τι
τινος/του	τινος/του
τινι/τω	τινι/τω
τινα	τι
τινες	τινα
τινων	τινων
τισι(ν)	τισι(ν)
τινας	τινα

Case	Sing	Pl	Sing	Pl	Sing	Pl
Nom	ὅστις	οἵτινες	ἥτις	αἵτινες	ὅτι	ἅτινα /ἅττα
Gen	οὗτινος /ὅτου	ᾧντινων /ὅτων	ἧστινος /ὅτου	ᾧντινων /ὅτων	οὗτινος /ὅτου	ᾧν
Dat	ᾧτινι/ ὅτῳ	οἷστισι(ν) /ὅτοις	ἧτινι/ ὅτῳ	αἷστισι(ν) /ὅτοις	ᾧτινι/ ὅτῳ	οἷς
Acc	ὄντινα	οὗστινας	ἦντινα	ἄστινας	ὅτι	ἅτινα /ἅττα

ὅς + τις = ὅστις
Indefinite Relative Pronouns
 [whoever; whatever]

καὶ οὐ πολλῶ χρόνῳ ὕστερον μετέμελε τοῖς Ἀθηναίοις, καὶ ἐψηφίσαντο, οἵτινες τὸν δῆμον ἐξηπάτησαν, προβολὰς αὐτῶν εἶναι. [1.7.35]

And not much later, it bothered the Athenians, and they voted that bonds be posted by those men, whoever deceived the people.

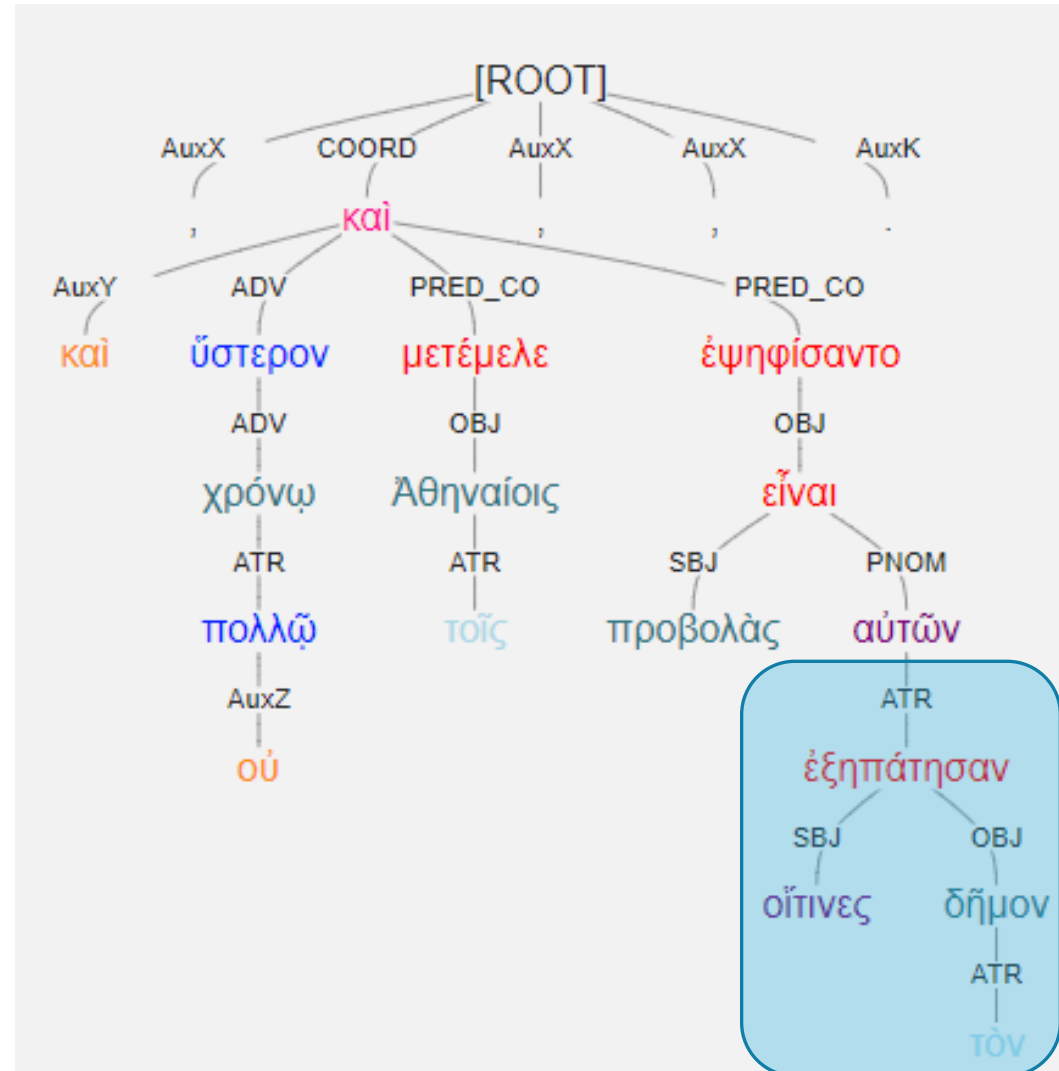

Relative Adjectives and Adverbs

Relative Adjectives [definite > indefinite]

- οἷος > ὁποῖος such as; of a kind that
- ὅσος > ὅπόσος as great, as many; all who

Relative Adverbs

- οὓ > ὅπου where; wherever
- ὅθεν > ὅπόθεν whence; from wherever
- οἶ > ὅποι whither; to wherever
- ἧ̃ > ὅπη by which [dat]; by whatever
- ὡς > ὅπως as, like; how

καὶ ταῦτα ὅπλα πάντ' ἦν ὀπόσοις ἄνθρωποι καὶ γῆν καὶ
ξύλα καὶ λίθους ἐργάζονται. [3.3.7]

*All these things, as many as
men use to work the earth
and wood and stone, were
weapons.*

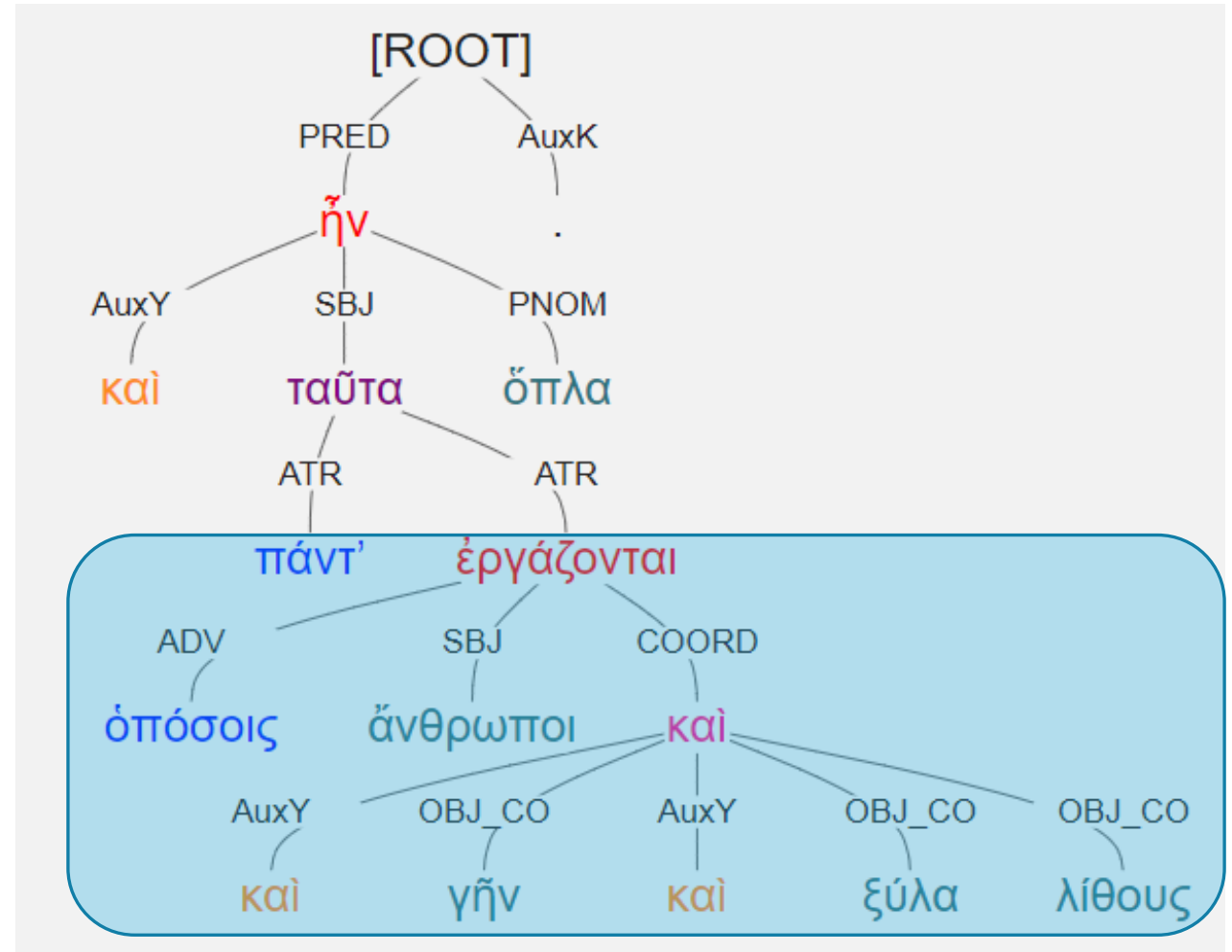

ἐδίδασκε τοὺς ἐν Πειραιεῖ οἷα χρή. [2.4.35]

He was teaching the men in the Peireios what sorts of things they needed [to do].

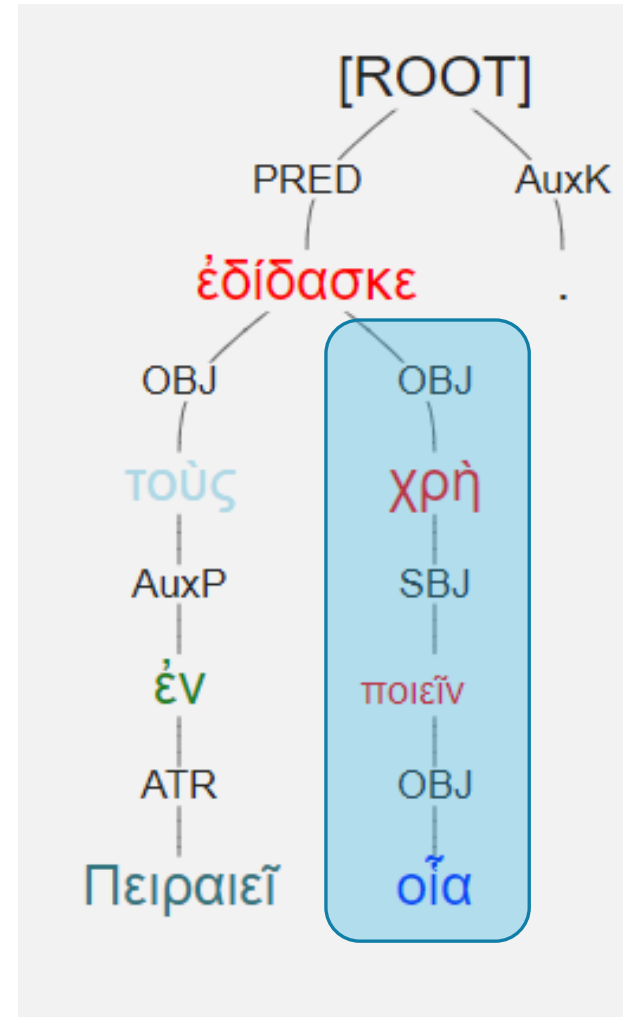

Correlatives

Some pronouns, adjectives, and adverbs correspond to each other

Often occur in pairs

- That one ... who
- so many ... how many ...
- There ... where ...
- Then ... when ...
- Thus ... how ...

Examples of Correlatives

Interrogative	<i>who?</i>	<i>how many?</i>	<i>when?</i>
Indefinite	<i>someone</i>	<i>of some quantity</i>	<i>some time</i>
Demonstrative	<i>this one</i>	<i>so many</i>	<i>then</i>
Relative	<i>who</i>	<i>as many as</i>	<i>when</i>
Indefinite Relative	<i>whoever</i>	<i>however many</i>	<i>whenever</i>

Interrogatives Direct or Indirect	Indefinite (Enclitic)	Demonstrative	Relative (Specific) or Exclamatory	Indefinite Relative or Indirect Interrogative
τίς <i>who?</i> <i>which? what?</i> <i>quī?</i>	τις <i>some one, any one, aliquis, quidam</i>	(ὁ, ὅς) ὅδε <i>this (here), hic</i> οὗτος <i>this, that is, ille</i> ἐκεῖνος <i>ille</i>	ὅς <i>who, which</i> <i>quī</i>	ὅστις <i>whoever, any one who</i> <i>quisquis, quicumque</i>
πότερος <i>which of two?</i> <i>uter?</i>	πότερος or ποτερός <i>one of two (rare)</i>	ἕτερος <i>the one or the other of two</i> <i>alter</i>	ὀπότερος <i>whichever of the two</i>	ὀπότερος <i>whichever of the two</i> <i>utercumque</i>
πόσος <i>how much? how many? quan- tus? quot?</i>	πόσος <i>of some quantity or number</i>	(τόσος) τοσόσδε } τοσοῦτος } <i>tantus, tot</i>	<i>so</i> <i>much,</i> <i>so</i> <i>many</i>	ὀπόσος <i>as</i> <i>much as,</i> <i>as many as</i> <i>quantus, quot</i> <i>quantuscumque, quotquot</i>
ποιός <i>of what sort?</i> <i>qualis?</i>	ποιός <i>of some sort</i>	(τοιός) τοιόσδε } τοιούτος }	<i>such</i> <i>talis</i>	ὀποιός <i>of which</i> <i>sort,</i> <i>(such) as</i> <i>qualis</i> <i>qualiscumque</i>
πηλίκος <i>how old?</i> <i>how large?</i>	πηλίκος <i>of some age,</i>	(τηλίκος) τηλικόσδε } τηλικούτος }	<i>so old,</i> <i>so</i> <i>young,</i> <i>so</i> <i>large,</i> <i>so</i> <i>great</i>	ὀπηλίκος <i>of which age,</i> <i>size, (as old, large) as</i> <i>of whatever age or size</i>

Correlative pronouns/adjectives
Smyth 340

Interrogatives = questions

Semi-colon used as a question mark.

τίς, τί without an accent [enclitic] = indefinite pronoun

- *Someone, something*

τίς, τί with an accent = direct or indirect interrogative pronoun

- *Who? What/Why?*

τίς γὰρ ἤδη καταλείπεται αὐτοῖς εὐμενής; [3.5.11]

- *For who remains who is well-disposed to them?*

οἱ δ' Ἀθηναῖοι ἠπόρουν τί χρὴ ποιεῖν. [2.2.11]

- *The Athenians were at a loss as to what it was necessary to do.*

Correlative adverbs, Smyth 346

	Interrogative: Direct or Indirect	Indefinite (Enclitic)	Demonstrative	Relative Specific	Indefinite or Indirect Interrogative
Place	ποῦ where?	πού somewhere	(ἐνθα) ἐνθάδε, ἐνταῦθα there ἐκεῖ yonder	οὗ where (ἐνθα where)	ὅπου where- (ever)
	πόθεν whence?	ποθέν from some place	(ἐνθεν) ἐνθένδε, ἐντεῦθεν thence ἐκεῖθεν from yonder	ὅθεν whence (ἐνθεν whence)	ὀπόθεν whence- (soever)
	ποιῖ whither?	ποιί to some place	(ἐνθα) ἐνθάδε, ἐνταῦθα thither ἐκεῖσε thither	οἶ whither (ἐνθα whither)	ὀποι whither- (soever)
Time	πότε when?	ποτέ some time, ever	τότε then	ὅτε when	ὀπότε when- (ever)
	πηνίκα at what time?		(τηνίκα) τηνικάδε } τηνικαῦτα } at that time	ήνίκα at which time	ὀπηνίκα at which time
Way	πῆ which way? how?	πή some way, somehow	(τῆ) τῆδε, ταύτη this way, thus	ἣ in which way, as	ὀπῆ in which way, as
Manner	πῶς how?	πώς somehow	(τώς), (ῶς) ῶδε, οὔτω (ς) thus, so, in this way ἐκείνως in that	ὡς as, how	ὀπῶς how

πῶς οὐ ταῦτα ἐκείνων ἀδικώτερα; [2.3.23]

How were these things not more unjust than those?

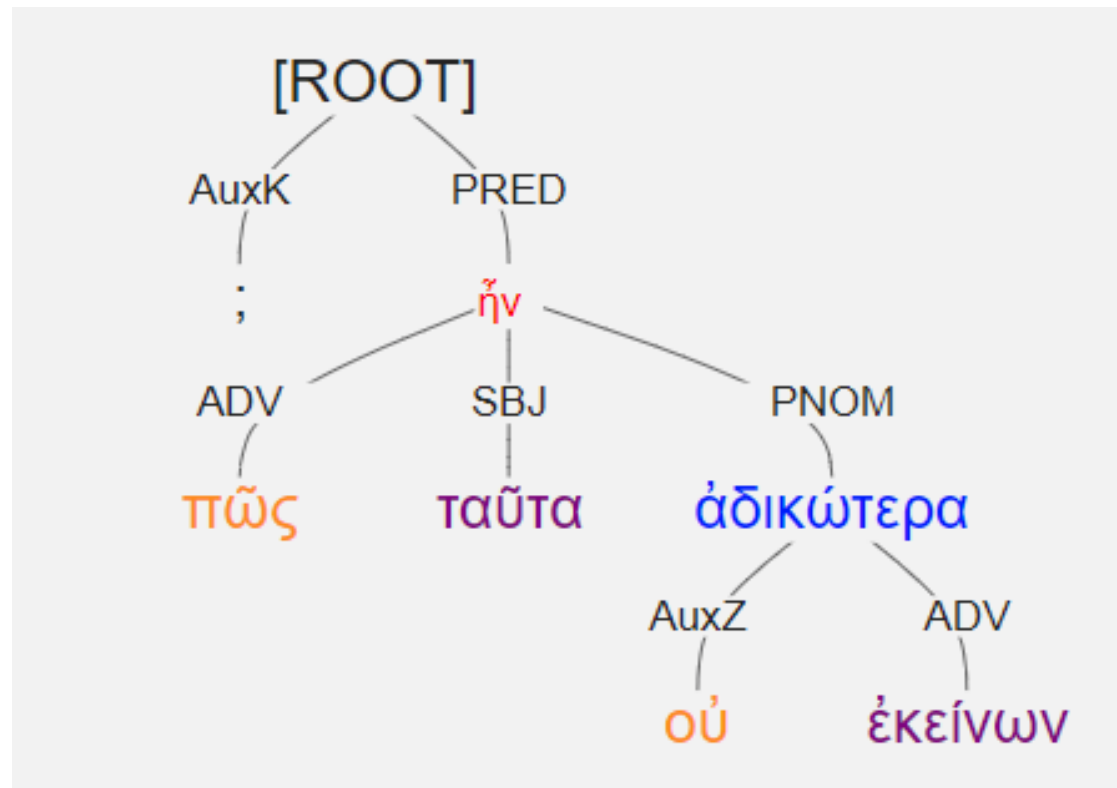

Summary of new vocabulary

Form	Meaning	Count	Rank	POS
ἄτε	<i>just as if</i>	26	298	adv
οἷος	<i>of what sort</i>	43	187	adj
	<i>of whatever</i>			
ὅπόσος	<i>number</i>	22	346	adj
ὅποτε	<i>whenever</i>	22	345	adv
ὅπου	<i>wherever</i>	21	374	adv
ὅπως	<i>however</i>	90	95	adv
ὅς	<i>who</i>	439	16	adj
ὅσος	<i>as many as</i>	115	70	adj
ὅστις	<i>whoever</i>	42	193	adj
τοιοῦτος	<i>such</i>	50	157	adj
τοσοῦτος	<i>so many</i>	24	328	adj

